

Anchor Bolts for use in concrete — UK Guidance

Distinction between cracked and non-cracked concrete

This DataSheet gives the 'other guidance' required by ETAG No 001 and applies to the use of anchors approved to the same ETAG when used in new and existing concrete structures in the UK, in which early thermal and shrinkage movements have substantially ceased at the time of the installation. Of the two movements, early thermal movement generally, will be the more significant but this can be assumed to have ceased after 28 days of casting the concrete. When aggregates with low shrinkage are used, it may be assumed that significant shrinkage will not take place after 56 days. With other aggregates, 90 days may be more appropriate. It has been assumed that the design, detailing and construction of the structure comply with the relevant regulations. In particular, it has been assumed that normal movement joints have been provided and the reinforcement detailing complies with common good practice.

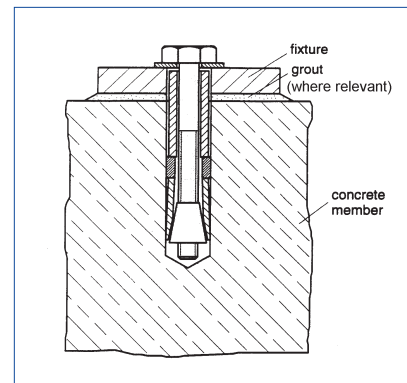

Definition of Non-Cracked Concrete

In defining non-cracked concrete it should be borne in mind that:

- the capacity of the anchors is not influenced by the presence of cracks at the time of the installation but rather the subsequent movement of these cracks. Only loads applied after the installation of the anchors are of interest
- imposed loads applied to floors vary with time and space and thus any realistic consideration of loading will be in terms of probability
- the load carried by anchors is generally independent of the imposed loading applied to the structure and thus there is joint probability involved
- cracks in concrete occur with a definite spacing between them. Whether an anchor actually coincides with a crack is also a matter of probabilities.

For these reasons non-cracked concrete is defined as:

Non-cracked concrete is concrete where the probability is acceptably low that either cracks will form after installation of anchors or the width of any existing cracks will increase significantly during the life of the anchors.

While a theoretical definition of this type is necessary to encapsulate the various considerations, practical design is likely to be carried out using guidance of the type described below.

Deemed-to-satisfy provisions

The provisions of the above definition may be deemed to be satisfied without any calculation in the different types of structural elements at the locations shown in Table 1. The fail-safe method in ETAG No 001 provides the following condition to assume non-cracked concrete: $s_1 + s_r < 0$.

Where: s_1 is the stress in the concrete caused by external loads including the anchorage loads, and compression is assigned negative values. s_r is the stress in the concrete due to restraint of internal and external imposed deformations.

In the figures (see Table 1), s_r has been assumed to be 0 so that only those regions likely to be in compression have been assumed to be non-cracked. More of the structure can be considered non-cracked in pre-stressed elements, where details of resulting stresses are known.

For unrestrained members, eg cantilevers, the tensile capacity of concrete is used to extend the zones of non-cracked concrete.

The figures apply to new structures but can also be applied to existing decanted and refurbished structures subject to:

- a structural appraisal having been carried out by a competent engineer to check that the structure is generally in a reasonably sound condition without significant deterioration
- there having been insignificant increase in loading after the installation of anchors.

In an existing building in use, ie where decanting does not take place, anchors can be installed in any location provided it is unlikely that a significant increase in loading will occur after the installation of anchors.

Table 1 Examples of locations of non-cracked concrete

Structural member	Non-cracked locations in the length of the member (shown hatched)	Non-cracked locations in cross section of member (taken at an external edge)
Solid slabs — simply supported		
Solid slabs — continuous		
Beams — simply supported		
Beams — continuous		
Ribbed floors		

Table 1 Examples of locations of non-cracked concrete (continued)

Structural member	Non-cracked locations in the length of the member (shown hatched)	Non-cracked locations in cross section of member (taken at an external edge)
Cantilever slabs		
Cantilever beams		
Columns and walls – except in the perimeters of single storey buildings and in the perimeters of top storeys of buildings		
Portal frame		

Note: Adjacent spans should not differ by more than 15% of the longer span

Bibliography

Guidance on the distinction between cracked and non-cracked concrete in relation to the use of anchors with European Technical Approvals within the UK.

A W Beeby, R S Narayanan. 1999. Construction Fixings Association

CFA Guidance Note European Technical Approvals for Construction Fixings 1998

ETAG No 001 *Guideline for European Technical Approval of Metal Anchors for use in Concrete*. EOTA. Published in the UK by British Board of Agrément.

Organisations

British Board of Agrément

Watford

Herts WD25 9BA.

Tel: 01923 665300

Fax: 01923 665301

e-mail: clientservices@bba.star.co.uk

Construction Fixings Association (CFA)

Tel: 01664 823687

Fax: 01664 823687

e-mail: info@fixingscfa.co.uk

www.fixingscfa.co.uk

European Organisation for Technical Approvals (EOTA)

Avenue des Arts 40 Kunstlaan

B-1040 Brussels.

Task Group

This guidance was prepared by a Task Group (see *Organisation*) set up by a BBA National Technical Committee (NTC1 *Metal Anchors for use in concrete*) in its role as Mirror Group to the EOTA Working Group *Anchors*. It is a summary of a more detailed discussion document (see *Bibliography*) and is provided to assist UK specifiers in the selection of fixings with European Technical Approvals (see *Bibliography*).

Members of the Task Group

Professor A W Beeby — University of Leeds

Mr C Billington — Trent Concrete Ltd (for Institute of Civil Engineers)

Dr S Cadden — The Rawlplug Company Ltd (for the CFA)

Mr G Gurney — British Board of Agrément

Mr A Keiller — Centre for Window and Cladding Technology

Professor R S Narayanan — Cadogan Teitz, Consulting Engineers

Dr S Popo-Ola — Imperial College (for the Steel Construction Institute)

Mr M T Salmon — Independent Fixing Consultants (for the CFA).